

PTC Creo® Parametric™

The Essential 3D Parametric CAD Solution

PTC Creo Parametric gives you exactly what you need: The most robust, scalable 3D product design toolset with more power, flexibility, and speed to help you accelerate your entire product development process.

Where breakthrough products begin

PTC Creo Parametric is a scalable, interoperable parametric solution for maximizing innovation, improving quality in 3D product design, and delivering faster time to value. The software helps you quickly deliver the most accurate digital models with the highest quality. In addition, high-fidelity digital models have full associativity so that product changes made anywhere can update deliverables everywhere. That's what it takes to achieve the digital product confidence needed before investing significant capital in sourcing, manufacturing capacity, and volume production. With a comprehensive library of CAD, CAID, CAM, and CAE extensions, PTC Creo Parametric has the ability to grow as your business and product development needs grow.

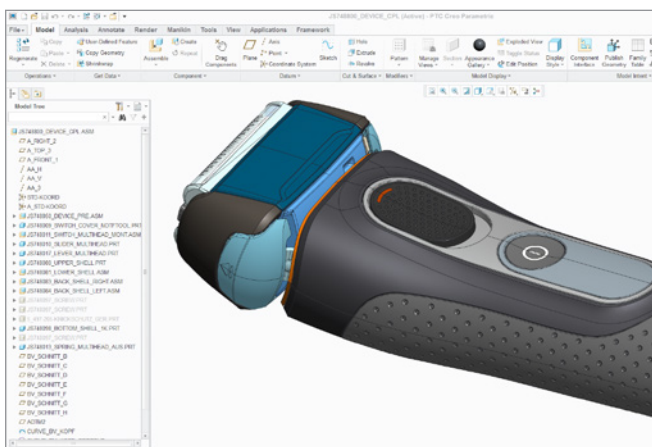

Create High Quality 3D models of your product designs.

Key benefits

- Increase productivity with more efficient and flexible 3D detailed design capabilities
- Quickly and easily create 3D models of any part or assembly
- Dedicated toolset for working with large assemblies
- Create manufacturing drawings automatically with complete confidence that they will always reflect your current design
- Improve design aesthetics with comprehensive surfacing capabilities
- Repurpose neutral and non PTC CAD data from customers and suppliers easily, avoiding the need to convert files or recreate 3D models from scratch
- Instant access to a parts library including screws, bolts, nuts, and washers
- Get instant access to comprehensive learning materials and tutorials from within the product to get productive faster

Never compromise

Based on the proven technology of Pro/ENGINEER® and chosen by tens of thousands of companies worldwide, PTC Creo Parametric offers the newest, most innovative 3D CAD capabilities for your detailed design process. As a design professional, you can't risk having CAD tools that compromise your product, process, or productivity. With the software, you never compromise because you have the exact tools you need to get the entire job done accurately and quickly.

PTC Creo Parametric capabilities

3D solid modeling

- Create precise geometry, regardless of model complexity
- Automatically dimension sketches for fast, easy reuse
- Quickly build robust engineering features such as rounds, chamfers, holes, and more
- Create part variants using family tables

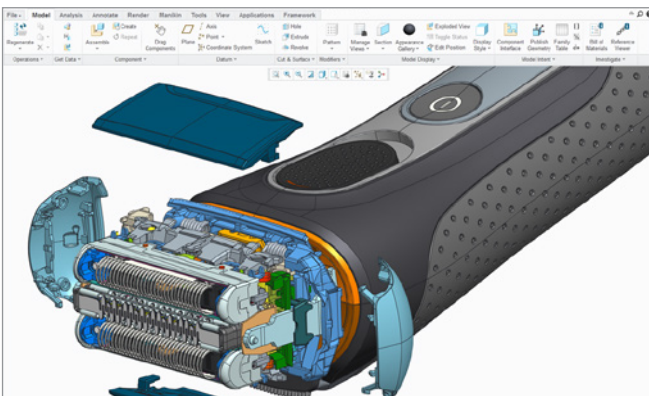

The intuitive user interface streamlines design tasks.

Robust assembly modeling

- Enjoy smarter, faster assembly modeling performance
- Create simplified representations 'on-the-fly'
- Share lightweight yet fully accurate model representations using the unique Shrinkwrap™ tool
- Leverage real-time collision detection

Detailed documentation including 2D and 3D drawings

- Create 2D and 3D drawings according to international standards, including ASME, ISO, and JIS
- Create an associative bill-of-material (BOM) and associated balloon notes automatically
- Automate the creation of drawings with templates

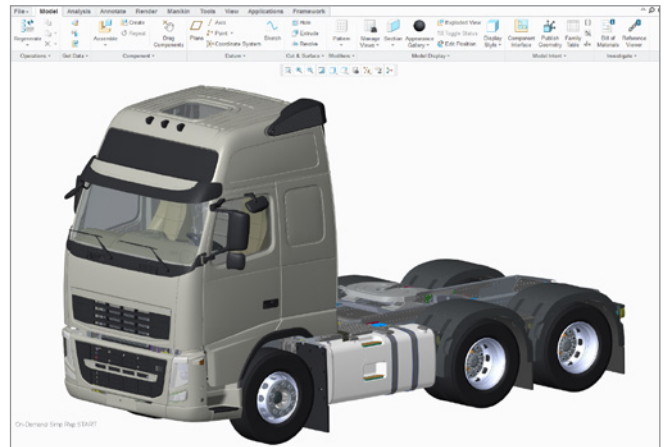

Build assembly models of any size faster using best-in-class component placement capabilities.

Technical surfacing

- Develop complex surface geometry using sweeps, blends, extends, offsets, and a variety of other specialized features
- Trim/extend surfaces using tools such as extrude, revolve, blend, and sweep
- Perform surface operations such as copy, merge, extend, and transform
- Define complex surface geometry

Freestyle surfacing

- Quickly create freeform shapes and surfaces using sub-divisional modeling capabilities
- High-quality, parameterized surfaces can be immediately reused in a 3D detailed design process
- Multilevel subdivisional modeling for more control over the surface, enabling finer detailing without altering the existing shape
- Parametrically control Freestyle geometry by aligning to existing curves or edges with tangency control

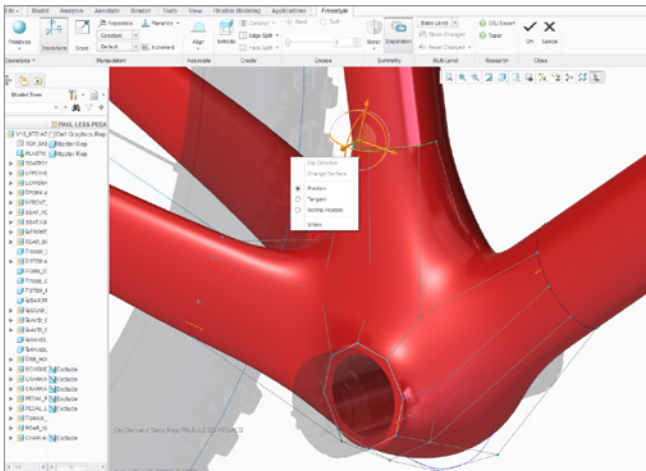

Accelerate concept design with PTC Creo Parametric.

Weld modeling and structural framework design

- Optimized user interface for the structural framework design process
- Define joining requirements
- Extract valuable information from the model, such as mass properties, clearances, interferences, and cost data
- Easily produce complete 2D weld documentation
- Intelligent component library and automatic creation of downstream deliverables for faster frame design than standard techniques

Sheetmetal modeling

- Create walls, bends, punches, notches, forms, and reliefs using the streamlined user interface
- Automatically generate flat patterns from 3D geometry
- Use a variety of bend allowance calculations to create flat patterns of the designs

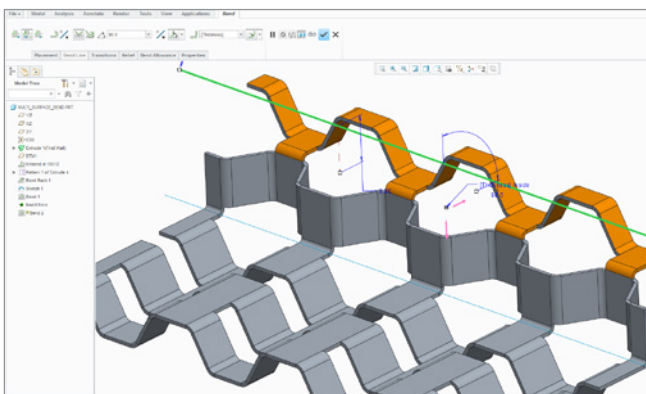

Create sheetmetal geometry using functionality to automatically apply bend relief, create sheetmetal rips, bend coplanar geometry, and more.

Digital human modeling

- Insert and manipulate a digital human inside your CAD model
- Gain valuable insight about interactions between your product and people who manufacture, use, and service the product earlier in the design cycle

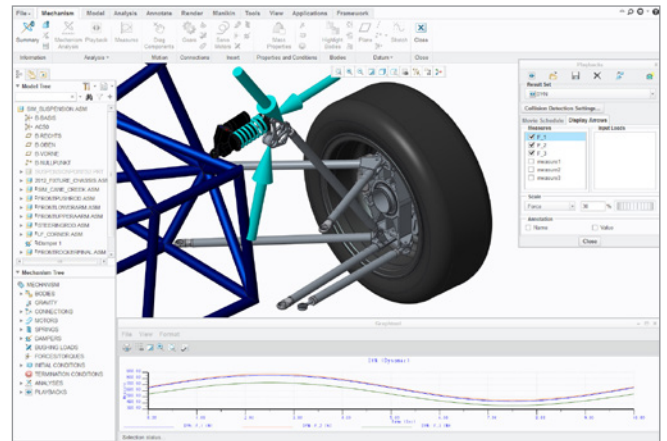

Mechanism Design lets you create mechanical connections and simulate motion on kinetic assemblies.

Analysis features

- Perform basic static structural analysis on parts and assemblies
- Validate the kinematic motion of your design
- Interoperability with PTC Mathcad® engineering calculation software lets you integrate PTC Mathcad worksheets with your design to predict behavior and drive critical parameters and dimensions (PTC Mathcad optionally available)
- Add Microsoft® Excel® files to your design
- Integrated analysis and measure tools including draft and 3D thickness evaluation

Graphic experience and integrated design animation

- Shade with reflections for displaying different material classes such as metal, glass, paint, and plastic. Produce realistic interaction representations of these appearance types on the model while still being able to dynamically make changes
- Create accurate, photorealistic images of products quickly, while rendering even the largest assemblies
- Make dynamic geometry changes while maintaining effects such as shadows, reflections, textures, and transparency
- Create assembly/disassembly animations directly from the modeling environment
- Reuse models easily, with the option to include mechanism simulation

Design for Additive Manufacturing

- Define settings for multiple 3D printers
- Position, scale and show a clipped view of the 3D model and support material on the printer tray
- Quickly perform 3D printability checks and easily correct identified issues
- Print parts and assemblies, define surface finishes, materials, colors and calculate build and support material directly from PTC Creo using a Stratasys Connex printer

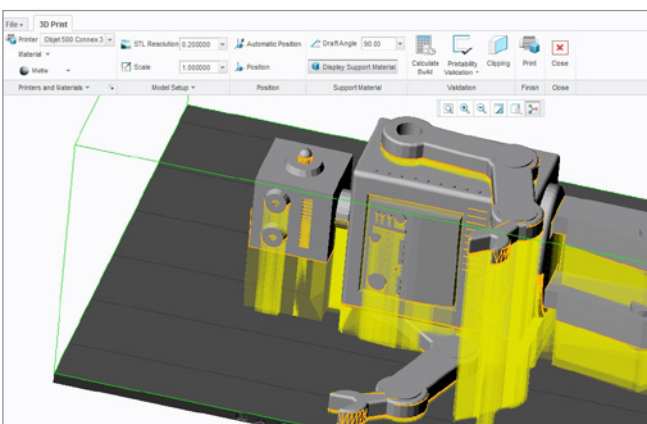

Position the model on the print tray and view the required supporting material in PTC Creo.

Data exchange

- Work with a number of standard file formats including STEP, IGES, DXF, STL, VRML, AutoCAD DWG, DXF (import of 3D with associated 2D), ACIS import/export, Parasolid import/export*
- With the use of *Unite* technology, convert data from other CAD systems including: CATIA®, Siemens® NX™, SolidWorks®, Autodesk®, and SolidEdge®
- Incorporate non-PTC Creo data directly into their designs without creating additional business objects or files to manage
- Support export of non-PTC Creo formats (CATIA, Siemens NX, SolidWorks) as well as associative updates with additional purchased capabilities*

Working with imported non-PTC Creo Data

- Use Import Data Doctor (IDD) to repair, modify, or featurize geometry imported into PTC Creo Parametric from external sources
- Check and report geometric defects in a model such as surfaces, edges, and vertices
- Use IDD's repair tool to find and close gaps, repair poorly defined wireframes, and repair unsatisfied tangency

Integrated NC capabilities

- Create 2-1/2-axis milling programs in less time
- Machine prismatic parts with 5-axis positioning
- Full support for multi-head machining centers with synchronization

Web capabilities provide instant access

- Internet/Intranet support for fast access to email, FTP, and the Web – all from within PTC Creo Parametric
- Seamless access to PTC Windchill® for content and process management

*Requires PTC Creo Collaboration Extensions

Complete library of parts, features, tools, and more

- Fully integrated fastener library
- Integrated web based component catalog
- Download predefined parts and symbols using J-Link Programmatic Interface
- Quickly position and insert fasteners and associated nuts, washers etc. using intelligent fastener capability

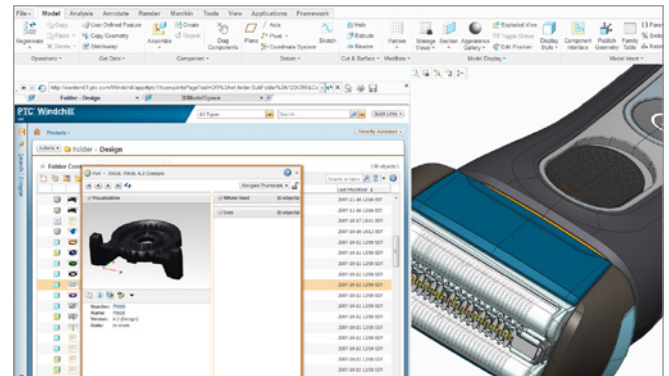

Leverage Web connectivity for information-gathering, part catalogs, and optional Product Data Management (PDM) and collaboration solution access.

Easy to expand, impossible to outgrow

The unlimited scalability of the software means you can easily add new users, new modules, and new capabilities as your business and your needs continue to grow, and you'll never have to worry about importing incompatible data or learning a new user interface. Add-on extensions seamlessly provide extended capabilities including the following products:

3D CAD – Advanced design solutions

PTC Creo provides a number of advanced, specialized capabilities to meet the broad range of designers' needs. From structural frameworks to digital human models, PTC Creo extensions help you capture more of your design in 3D

- | | |
|--|---|
| <ul style="list-style-type: none"> • PTC Creo Flexible Modeling Extension • PTC Creo Options Modeler Extension • PTC Creo Layout Extension • PTC Creo Advanced Assembly Extension • PTC Creo ECAD-MCAD Collaboration Extension • PTC Creo Advanced Framework Extension | <ul style="list-style-type: none"> • PTC Creo Manikin Extension • PTC Creo Piping and Cabling Extension • PTC Creo Intelligent Fastener Extension • PTC Creo Harness Manufacturing Extension • PTC Creo Design Exploration Extension |
|--|---|

3D CAID extensions

PTC Creo delivers the capabilities you need to create the precise shapes, surfaces, and aesthetics of your design. Unleash your creativity and show your designs "in the best light" with PTC Creo CAID products

- | | |
|--|--|
| <ul style="list-style-type: none"> • PTC Creo Interactive Surface Design Extension • PTC Creo Advanced Rendering Extension | <ul style="list-style-type: none"> • PTC Creo Reverse Engineering Extension |
|--|--|

3D CAE extensions

Verifying the performance of your designs early in the process can help you get to the end-result faster. That's why PTC Creo provides design engineers with a broad range of integrated simulation and analysis capabilities to help them design with confidence

- | | |
|---|---|
| <ul style="list-style-type: none"> • PTC Creo Simulation Extension • PTC Creo Advanced Simulation Extension • PTC Creo Behavioral Modeling Extension • PTC Creo Fatigue Advisor Extension • PTC Creo Mechanism Dynamics Option | <ul style="list-style-type: none"> • PTC Creo Mold Analysis Extension • PTC Creo Spark Analysis Extension • PTC Creo Manikin Analysis Extension • PTC Creo Tolerance Analysis Extension |
|---|---|

3D NC and Tooling extensions

Streamlining tooling design and manufacture can accelerate your time to market. PTC Creo NC and Tooling solutions provide a broad range of mold, tool, and die design and machining capabilities so you can leverage your 3D CAD data – thereby saving time and reducing errors

- | | |
|--|---|
| <ul style="list-style-type: none"> • PTC Creo Progressive Die Extension • PTC Creo Expert Moldbase Extension • PTC Creo NC Sheetmetal Extension • PTC Creo Prismatic and Multi-Surface Milling Extension | <ul style="list-style-type: none"> • PTC Creo Production Machining Extension • PTC Creo Complete Machining Extension • PTC Creo Complete Mold Design Extension • PTC Creo Computer-Aided Verification Extension • PTC Creo Tool Design Extension |
|--|---|

Multi-CAD data exchange and other products

PTC Creo Parametric provides native data exchange with numerous 2D and 3D file formats. The following add-on extensions also provide associative interoperability and other capabilities, such as distributed processing, interoperability with 3rd-party applications, and more

- | | |
|---|---|
| <ul style="list-style-type: none"> • PTC Creo Distributed Batch Extension • PTC Creo Collaboration Extension for CATIA V4/V5 • PTC Creo Collaboration Extension for SolidWorks | <ul style="list-style-type: none"> • PTC Creo Collaboration Extension for UG/NX • PTC Creo Interface for JT • PTC Creo Legacy Data Migration Extension |
|---|---|

Platform support and system requirements

Please visit the [PTC support page](#) for the most up-to-date platform support and system requirements.

For more information, visit: PTC.com/product/creo or contact your local sales representative.

© 2015, PTC Inc. All rights reserved. Information described herein is furnished for informational use only, is subject to change without notice, and should not be taken as a guarantee, commitment, condition or offer by PTC. PTC, the PTC logo, Product & Service Advantage, Creo, Elements/Direct, Windchill, Mathcad, Arbortext, PTC Integrity, Servigistics, ThingWorx, ProductCloud and all other PTC product names and logos are trademarks or registered trademarks of PTC and/or its subsidiaries in the United States and other countries. All other product or company names are property of their respective owners. The timing of any product release, including any features or functionality, is subject to change at PTC's discretion.

J5685-PTC-Creo-Parametric-DS-EN-0515

What is PTC Creo?

PTC Creo Parametric is an integral part of the PTC Creo family of product design software.

PTC Creo is a scalable, interoperable suite of product design software that delivers fast time to value. It helps teams create, analyze, view, and leverage product designs downstream utilizing 2D CAD, 3D CAD, parametric, and direct modeling.